

Owners Installation, Operation, and Safety Manual

FILL-RITE.

Hand and Air Operated Pumps



Chemical, Lubricant, and Diesel Exhaust Fluid (DEF) Transfer Pumps

Models FR20V, FRHP32V, FRAP32V

Thank You!

Thank you for your purchase of a Fill-Rite pump! Fill-Rite products are known around the world for providing value that comes from superior performance, user friendly design, long service life, and solid, simple engineering. Our heritage and experience give you peace of mind.

Rest Easy – It's Tuthill!

About This Manual

From initial concept and design through its final production, your Fill-Rite pump is built to give you years of trouble free use. To ensure it provides that service, **it is critical that you read this entire manual prior to attempting to install or operate your new pump.** Become familiar with the terms and diagrams, and pay close attention to the highlighted areas with the following labels:



WARNING! Emphasizes an area in which personal injury or even death could result from failure to follow instructions properly. Mechanical damage may also occur.



CAUTION! Failure to observe a "Caution" can cause damage to the equipment.



IMPORTANT! These boxes contain information that illustrates a point that may save time or may be key to proper operation, or clarifies a step.

At Fill-Rite, your satisfaction with our products is paramount to us. If you have questions or need assistance with your product, please contact us at 1-800-634-2695 (M-F 8 AM–5 PM EST).

Safety Information



WARNING! To ensure safe and proper operation of your equipment, it is critical to read and adhere to all of the following safety warnings and precautions. Improper installation or use of this product can cause damage to the device and serious bodily injury or death!

- 1) When using the FRHP32V and FRAP32V with Diesel Exhaust Fluid, maintaining the purity of the DEF / AUS32 (Aqueous Urea Solution 32.5%) is critical; as such, it is imperative once the system is assembled, it must remain sealed to ensure the integrity of the fluid. Breaking the seal on the system can lead to fluid contamination.
- 2) After dispensing DEF be certain to drain all the fluid from the nozzle, making sure it is pointing downward when stored. DEF remaining in the nozzle tip and exposed to air will crystallize and can plug the nozzle.
- 3) **DO NOT** lay the dispensing nozzle on the ground or any surface that may contaminate the nozzle tip as this can compromise the purity of the DEF.
- 4) The base is designed to mount directly to the barrel bung; as such it has 2" NPS threads. Plumbing sealant appropriate for the fluids and chemicals being dispensed is highly recommended; the 2" threaded bung mount does not require sealant.
- 5) Storage tanks should be securely anchored to prevent shifting or tipping when full or empty.
- 6) If the pump will see periods of low or no use, flush it regularly when pumping DEF, corrosive materials, or fluids that harden. If the pump is used for DEF, use only DEF or de-ionized water to flush the pump (FRHP32V and FRAP32V applications).
- 7) DO NOT use the pump with fluids intended for human consumption.
- 8) **WARNING!** This pump is not for use with fluids that have a flash point below 100°F (37.8°C, ie: gasoline, alcohol). Refer to NFPA 325M (Fire Hazard Properties of Flammable Liquids, Gases, and Volatile Solids) for flash points of common liquids. Static electricity buildup and discharge could result in arc and explosion.
- 9) On hand operated pumps, leave the handle in the down position when not in use to prevent accidental dispensing of fluid.

Installation

FR20V and FRHP32V Hand Operated Pumps

Installation

- 1) Apply thread sealant tape or compound (appropriate for the fluid to be pumped) to the suction tube threads; screw tube into the pump inlet.
- 2) Slide suction pipe into tank or barrel.
- 3) Screw pump into tank or barrel application until the spout faces the desired direction for dispensing.
- 4) Tighten the lock ring securely onto the tank or barrel.
- 5) If applicable, attach dispensing hose to spout outlet; clamp securely in place.

FRAP32V Air Operated Pump

Installation

- 1) Apply thread sealant tape or compound (appropriate for the fluid to be pumped) to the suction tube threads; screw tube into the pump inlet.
- 2) Adjust length of suction tube to desired level.
- 3) Screw pump into tank or barrel application until the spout faces the desired direction for dispensing.
- 4) Tighten the lock ring securely onto the tank or barrel
- 5) Attach air supply line to air inlet on pump.



WARNING! DO NOT EXCEED 100 psi AIR PRESSURE ON AIR SUPPLY LINE!

- 6) Pull up adjusting knob on top of the regulator.
- 7) Open air inlet valve to begin flow of fluid; discharge into a suitable container.
- 8) Adjust air pressure by rotating the knob on top of the regulator until a smooth flow is achieved.
- 9) Push regulator knob down to lock it into place.
- 10) Close air inlet valve to stop flow.
- 11) If applicable, attach dispensing hose to spout outlet; clamp securely in place.

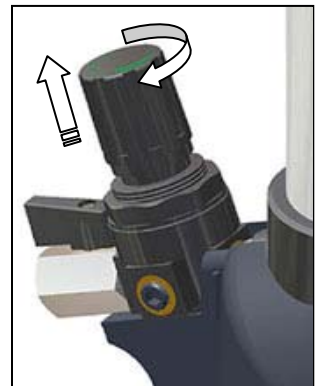



IMPORTANT! Tank Venting: In most cases it is desirable to vent the container being pumped from to prevent possible collapsing. The FR20V and FRHP32V hand pumps are self venting when screwed into a typical barrel. This is particularly important when working with Diesel Exhaust Fluid as exposure to air will crystallize the fluid instantly. It is critical to maintain the seal to a barrel or drum of Diesel Exhaust Fluid to maintain the integrity of the fluid.

About Diesel Exhaust Fluid (DEF)

The Fill-Rite DEF pump is designed to pump AUS32 (Aqueous Urea Solution 32.5%), better known as Diesel Exhaust Fluid, or “DEF”.

AUS32 is used by modern diesel engines which are equipped with an SCR (Selective Catalytic Reduction) system. DEF never comes into contact with the fuel; the common misconception is that it is an additive. DEF is carried onboard the vehicle in its own storage tank. It is injected into the exhaust gases as a post combustion process through an SCR where it breaks harmful NOx (Nitrous Oxide) emissions down into mostly Nitrogen and Oxygen.

Because the specific purity of the AUS32 solution is critical to the catalytic reaction, the Fill-Rite DEF pump is designed to maintain the integrity by using components made of materials that will not taint or alter the solutions chemical structure.



IMPORTANT! After initial assembly and installation, flush the entire dispensing system by pumping 1 - 2 gallons of DEF through it. This purges the system of air, and ensures any impurities that may have been in the system are washed out. Dispose of the Diesel Exhaust Fluid used to flush the system using approved Diesel Exhaust Fluid handling procedures; do not return the fluid to the drum or tote, or use it in a vehicle.

Trouble Shooting

FR70V & FRHP32V Hand Pumps		
Problem	Possible Cause	Solution
Pump will not prime	<ul style="list-style-type: none"> Suction line problem Jammed check valve Fluid incompatibility 	<ul style="list-style-type: none"> Check for leaks in suction line. Inspect inlet and piston valves. Consult fluid mfg. for compatibility with wetted materials.
Low pump capacity	<ul style="list-style-type: none"> Excessive dirt in nozzle screen Suction line problem 	<ul style="list-style-type: none"> Remove and clean screen. Check for leaks in suction line.
Pump fluid leakage	<ul style="list-style-type: none"> Dirty seal Bad seal Gasket leakage Fluid incompatibility 	<ul style="list-style-type: none"> Clean O-ring and seat area. Replace seal. Tighten covers and joints. Consult fluid mfg. for compatibility with wetted materials.

FRAP32V Air Operated Pump		
Problem	Possible Cause	Solution
Pump air piston does not operate	<ul style="list-style-type: none"> Air pressure is too low; minimum recommended air pressure is 30 psi (2 bar) Piston frozen in place (frost on air cylinder)* 	<ul style="list-style-type: none"> Increase air supply pressure to between 30 psi and 100 psi (2 bar to 6 bar). Close air inlet valve and allow piston & cylinder to thaw (see * note below).
Air piston stalls	<ul style="list-style-type: none"> Low air pressure, or pressure has dropped below 30 psi (2 bar) Piston frozen (see above) 	<ul style="list-style-type: none"> Close & re-open air inlet valve. If stalling occurs regularly, adjust the regulator to increase the air pressure.

*After periods of extensive use, usually with a hose kit, the air piston on the FRAP32V air pump may freeze because of excess moisture in the air supply line. If this condition persists, install a filter, filter / lubricator, or a water separator to reduce moisture content in the air supply to the pump.

Technical Information and Specifications

FR20V & FRHP32V

Technical Data

Output 11 oz per stroke (33 ml)

Fluid Compatibility (FR20V, FRHP32V, FRAP32V)

Engine oils Diesel Antifreeze Paraffin Gear oils
Hydraulic oils Mild acids* Degreasers

DEF Compatibility (FRHP32V & FRAP32V)

AUS32 (Aqueous Urea Solution 32.5%) Diesel Exhaust Fluid

Wetted Materials (all pumps)

Polypropylene (body and valves)
Stainless Steel (inlet screen)
Fluorocarbon (O-rings)

* Before using with acids or aggressive chemicals, check compatibility of wetted materials with the chemical mfg.

FRAP32V

Technical Data

Ratio	1:1
Air Pressure Regulator	100 psi
Air Inlet	1/4" BSP
Maximum Air Pressure	100 psi
Minimum Air Pressure	30 psi
Air Consumption	30 gal/min
Exhaust	Double Baffled
Maximum Sound Level @ 1m (3')	74 db

Output Data (approximately 8.5 oz/stroke when fully primed)

Hydraulic Oils (ISO 32)	0 - 5 GPM
Lubrication Oils (ISO 68)	0 - 4 GPM
Gear Oils (ISO 220)	0 - 2.5 GPM
Diesel Exhaust Fluid (AUS32)	0 - 6.5 GPM

Minimum Operating Temperature

It is recommended that the pump is not used below 36 F because ice formation may cause the regulator to malfunction.

Accessories

The following accessories are available to help you tailor your pump to your specific needs.

Part Number	Description	FR20V	FRHP32V	FRAP32V
KITHA32V	6' Hose and Ball Valve Kit	X	X	
KITHA32VMN	6" Hose and Manual Nozzle Kit			X
KITFR55DU	Drum / Barrel Tote Kit (wheeled platform for drum mobility)	X	X	X

Fill-Rite offers a wide variety of DEF & chemical dispensing pumps, meters, and accessories. Contact your Fill-Rite distributor for additional information on this equipment.

Tuthill Product Warranty

Tuthill Transfer Systems ("Manufacturer") warrants each consumer buyer of its Fill-Rite products ("Buyer") from the date of invoice or sales receipt, that goods of its manufacture ("Goods") shall be free from defects of materials and workmanship. Duration of the warranty is as follows:

- Heavy Duty Products – Two Years
- Standard Duty Products – One Year
- **Economy Duty Products – One Year (FR20V, FRHP32V, FRAP32V)**
- Cabinet Pumps, Parts, and Accessories – One Year

Manufacturers sole obligation under the foregoing warranties will be limited to either – at Manufacturers option – repairing or replacing defective goods (subject to limitations hereinafter provided) or refunding the purchase price for such Goods theretofore paid by the buyer, and Buyers exclusive remedy for breach of any such warranties will be enforcement of such obligations of the Manufacturer. If the Manufacturer so requests the return of such Goods, the Goods will be redelivered to the manufacturer in accordance with Manufacturers instructions FOB Factory. The remedies contained herein shall constitute the sole recourse of the Buyer against the Manufacturer for breach of warranty. **IN NO EVENT SHALL THE MANUFACTURER'S LIABILITY FOR ANY CLAIM FOR DAMAGES ARISING OUT OF THE MANUFACTURE, SALE, DELIVERY, OR USE OF THE GOODS EXCEED THE PURCHASE PRICE.** The foregoing warranties will not extend to goods subject to misuse, neglect, accident, improper installation or maintenance, or have been repaired by anyone other than the Manufacturer or its authorized representative. **THE FOREGOING WARRANTIES ARE EXCLUSIVE AND IN LIEU OF ALL OTHER WARRANTIES OF MERCHANTABILITY, FITNESS FOR PURPOSE OF ANY OTHER TYPE, WHETHER EXPRESSED OR IMPLIED.** No person may vary the forgoing warranties or remedies, except in writing signed by a duly authorized officer of the Manufacturer. The Buyer's acceptance of delivery of the Goods constitutes acceptance of the foregoing warranties and remedies, and all conditions and limitations thereof.

Model Number		UPC Bar Code	
Manufacture Date		Serial Number	

Tuthill Transfer Systems recommends you retain your receipt as proof of purchase date should warranty service be required.