

FR319VB S & E Data Sheet

Technical Information

Motor	
Power -AC 115, 230, 115/230	115/230
HZ 50, 60, 50/60	50/60
Power - DC 12, 24, 12/24	N/A
HP (horsepower) rating	¾
Power cord length	N/A
Power cord gauge	N/A
Power cord DC battery connectors	N/A
Amps (FLA)	9.8/4.9 11.4/5.7
RPM	1725/1425
Duty cycle	30 min
Thermal protection switch	Yes
Circuit protection fuse	None
Certification	None
Pump	
Type- rotary, diaphragm, gear, vane	Vane
GPM in supplied configuration	26.6
GPM open flow - no hose or nozzle	33.4
By-pass pressure rating (psi) - Max	21
Dry vac (in Hg)	12
Head- Max	N/A
Anti-siphon valve	Optional
Inlet - Size / Thread	1.25" / NPT
Outlet – Size / Thread	1" / NPT
Mount	bung
Materials of construction -pump housing	Cast Iron
Materials of construction- wetted material	Fluorocarbon / Buna
Rotor materials of construction	Bronze
Rotor vane material of construction	Carbon
Compatible fluids	Diesel Fuel, Kerosene, Heptane, Hexane, Mineral Spirits
Strainer mesh size	.04"
Warranty (yr)	2 Years

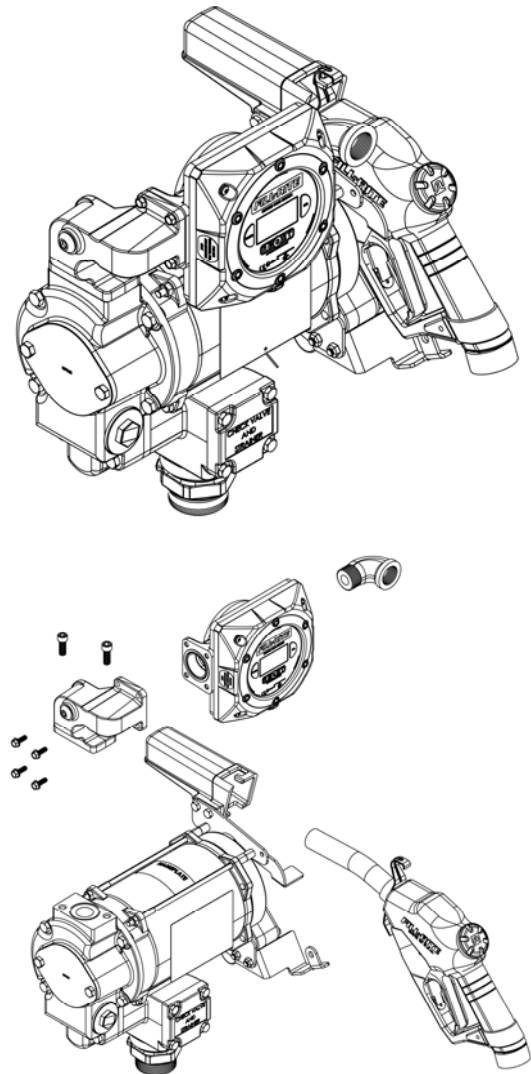

Dimensional Information

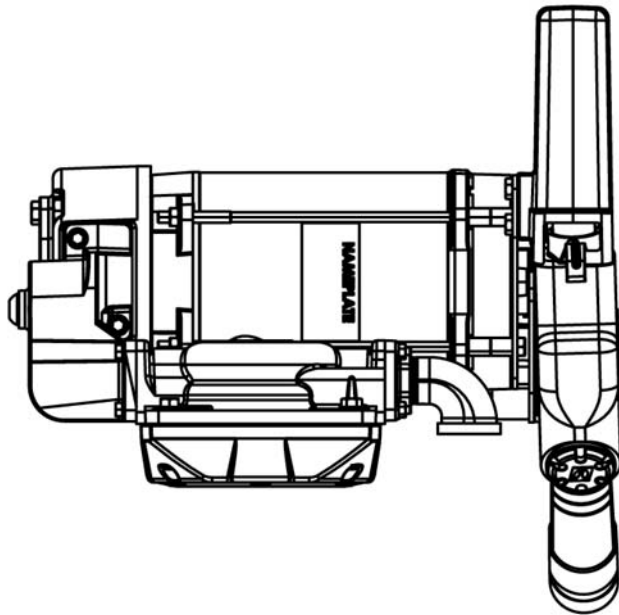

Measurements	
Overall Height	19.4"
Overall Width	17"
Overall Depth	17"
Intake Center Line to Discharge	2"
Intake Center Line to back of	8.5"
Shipping Weight	94 lbs.
Box Dimensions	21" L
	20" W
	18" H
Qty per Pallet	8

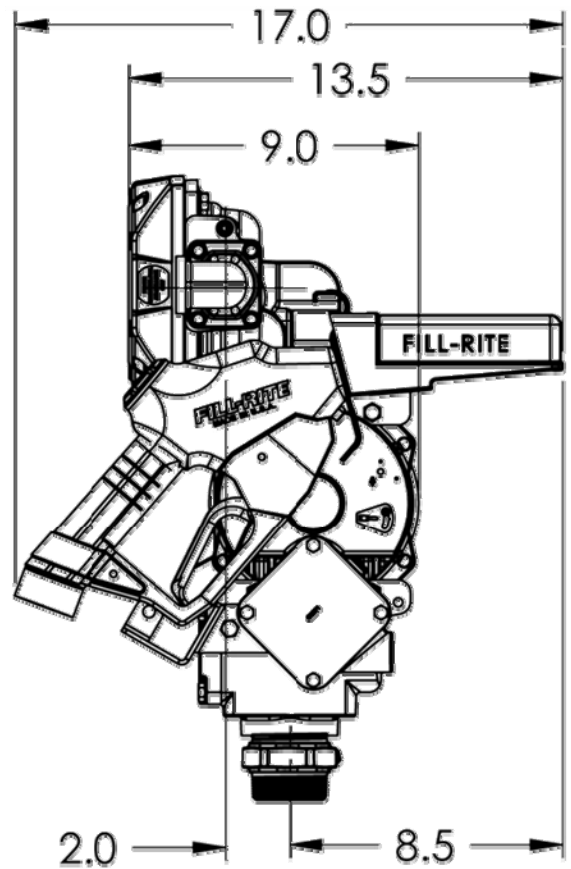
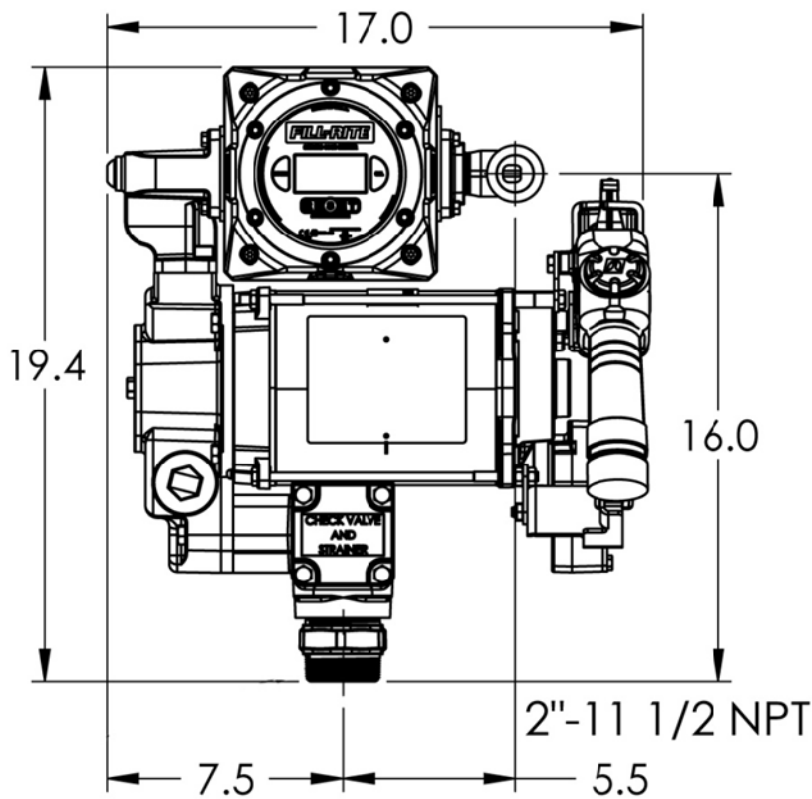

Performance Information

Pressure vs. GPM*			
psi	GPM	Amp	Notes
9	35	9.01	
10	34.9	9.1	
12	34	9.22	
14	31.7	9.37	
16	28.3	9.47	
18	24.6	9.48	
20	18.8	9.46	
21	17.1	9.57	
21	0	9.13	Bypass
16	27.7	9.48	18' x 1" Manual Nozzle
16.5	26.6	9.47	18' x 1" Ultra High Flow Nozzle
17	27.5	9.5	20' x 1" Manual Nozzle
17.5	26.3	9.51	20' x 1" Ultra High Flow Nozzle

*Performance figures based on diesel fuel.

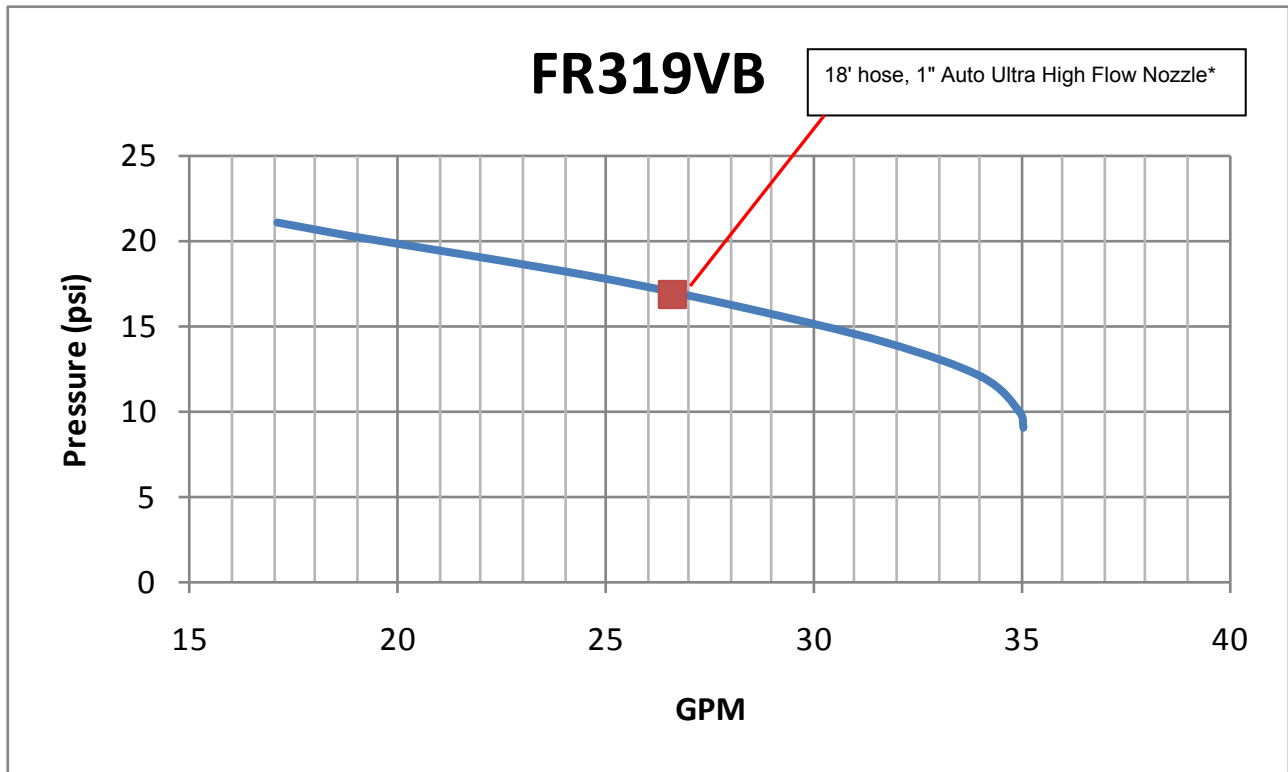

Changes in temperatures, fluid viscosity, and system accessories may shift the performance curves.

Accessories and Kits

Accessories	
Suction pipe material	N/A
Suction pipe length- extended/not extended	N/A
Nozzle- size	1" Ultra High Flow
Nozzle- manual / automatic	Automatic
Hose liquid materials compatibility	Diesel Fuel, Kerosene, Heptane, Hexane, Mineral Spirits
Hose diameter	1"
Hose length	18'
Hose static wire (Y/N)	Y

Kit #	Description
KIT300SW	Switch lever, attaching hardware
KIT300JC	Junction box cover, O-ring seal, attaching hardware
KIT300BV	Bypass cap, O-ring seals, bypass body and poppet, spring, attaching hardware
KIT700SL	O-ring seals, retaining ring, nickel plated seals, stainless steel seals and spring
KIT300RG	Rotor, vanes, O-ring seals and attaching hardware
KIT700BG	Inlet adapter, AST 2 x 1-1/4
KIT300SG	Pressure relief valve, O-ring seals, gasket, check valve body, stem, and insert, attaching hardware, cover
KIT300NB	Nozzle boot, attaching hardware
KIT300BD	Gaskets, O-ring seals, bypass cap, flange cover
KIT300NR	Nozzle retainer, attaching hardware
KIT300OT	Outlet flange, O-ring seal, attaching hardware
KIT700AS	Anti-siphon valve, Teflon tape, elbow adapter, stainless steel braided hose, attaching hardware

FILL-RITE®

The Most Trusted Name in Pumps and Meters

900D S & E Data Sheet

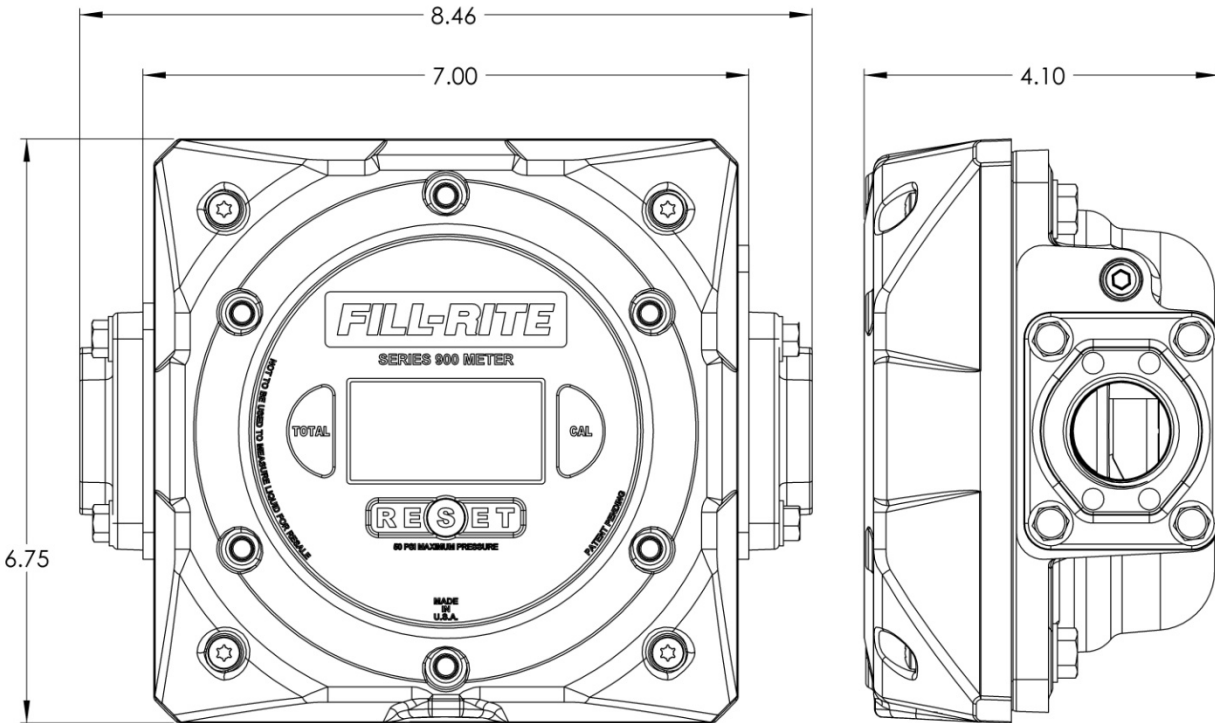

Technical Information / Specifications

Accuracy: $\pm 1.25\%^*$ **Flow Rate:** 6 to 40 GPM (23 to 151 LPM) **Repeatability:** $\pm 0.25\%$

Pressure Rating: 50 psi

Calibrations Settings: Ounces, Pints, Quarts, Liters, Gallons, and one Special Unit of Measure option.

Resettable Counter: 4 digit resettable counter.

Master Totalizer: 7 Digit non-resettable totalizer, 7 digit resettable totalizer

Construction: Housing: Aluminum **Measurement System:** Nutating Disc **Seals:** Buna

Certifications: UL 25 (US & Canada) on mechanical drive mechanism / UL 913 Pending

Fluid Compatibility

The 900D series meter **IS compatible** with the following fluids:

Diesel Fuel Kerosene Mineral Spirits Heptane Hexane

The 900D series meter **IS NOT compatible** with the following fluids:

Bleach Hydrochloric Acid Ink Sulfuric Acid Salt Water Gasoline



Tuthill Transfer Systems
Fort Wayne, Indiana
(800) 634-2695
www.tuthill.com

Features and Benefits

Large, highly visible, easy to read display.

Powered by 2 "AA" batteries (expected 4 – 6 years of service life in normal use).

"Membrane" keypad keeps moisture out and provides excellent continuous seal to the elements, even in the harshest environments.

Operating Temperature Range: -10 °- 180 ° F (-30 ° – 180 ° for diesel units with auxiliary power).

Rotatable housing allows horizontal or vertical mounting (remove 4 Torx screws and rotate display).

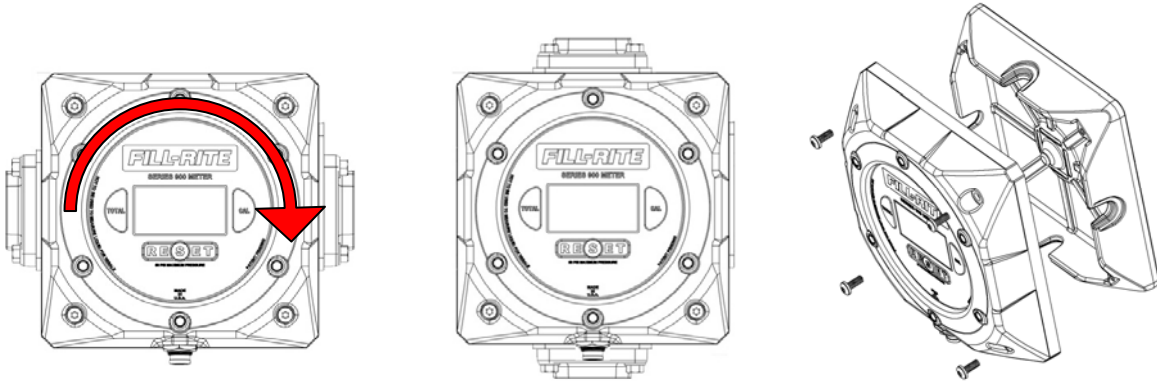

NPT threads standard; BSP threads available:
 NPT: 1" & 1.5"
 BSPT: 1" & 1.5"

900D / 900DP Performance Chart

Typical Performance Characteristics on Diesel Fuel

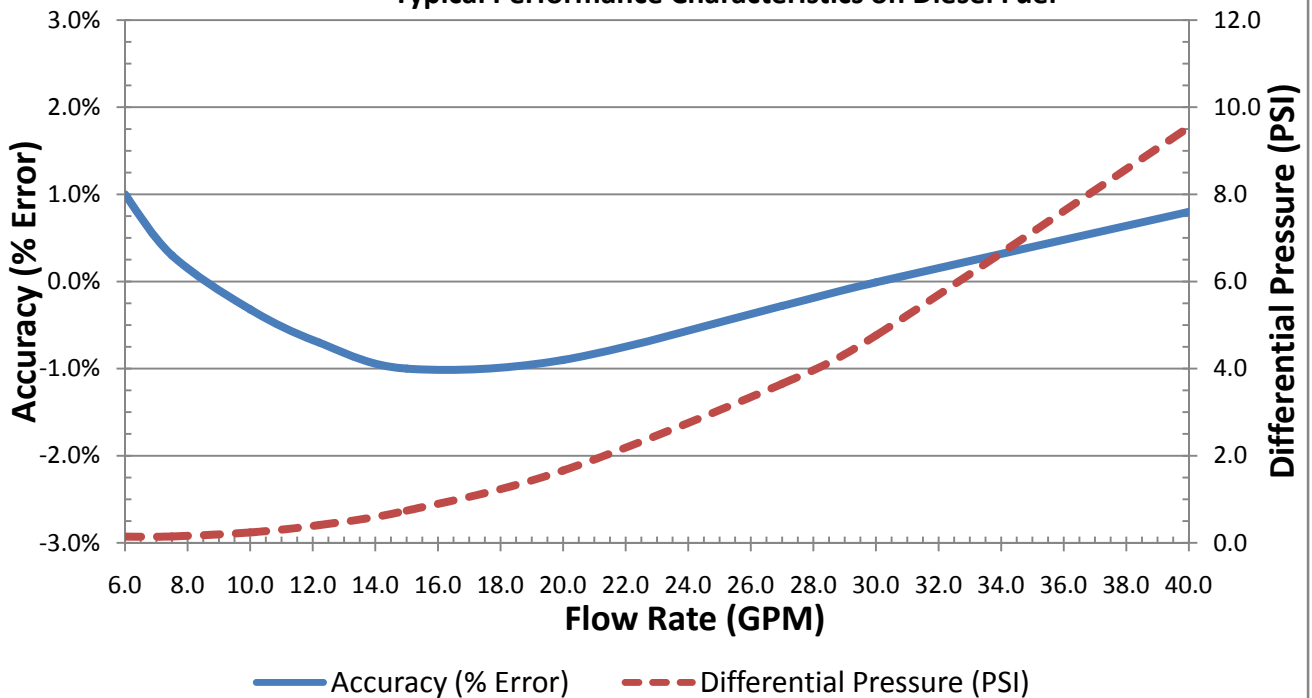

Changes in temperatures, fluid viscosity, and system accessories may shift the performance curves